

MODELLBAHN DIGITAL

Peter Stärz – Dresdener Str. 68 – 02977 Hoyerswerda - ☎ 03571/404027
www.firma-staerz.de - peter.staerz@t-online.de



Accessory decoder module kit for Selectrix®

**WD2
v4-2007**

for 8 turnouts, signals, uncouplers, relays

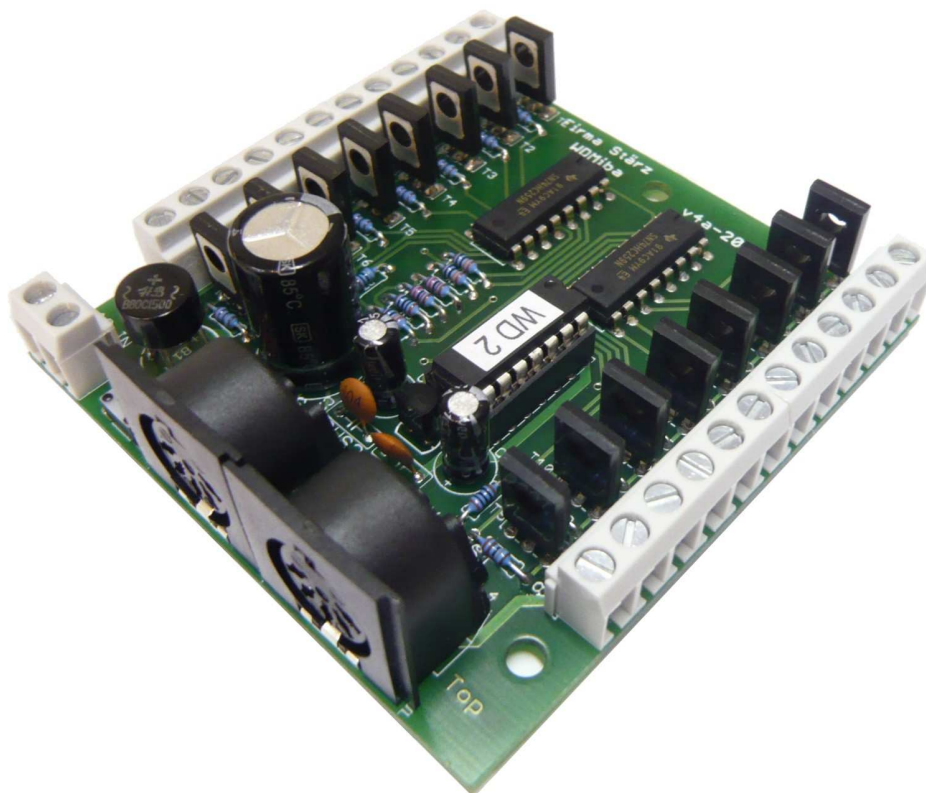

Degree of difficulty: **easy**
average
difficult

Required capabilities:

- Easy assembling and soldering of the PCB

The accessory decoder module WDMiba (with software WD2) is an output device for controlling 8 turnouts, light signals, uncouplers or relays of a Selectrix controlled model railway layout.

The device controls solenoid powered turnouts and other accessories through current pulses. For light signals there is a continuous current option. If you need to control accessories equipped with a motor using WD-2, you will need to purchase the optional EP WDMot extension module.

Decoder's SX bus address and output mode (pulse or continuous current) can be configured through SX bus individually for each of the 8 output channels.

When the Selectrix system is switched on, accessory decoder reports back to the central unit the last state of it's' channels (position of turnouts etc.) before the system was switched off the last time.

The illustration shows the decoder module kit WDMiba soldered with accessory kit EWDMiba, containing clamps, SX bus connectors and an SX bus cable.

Table of content:

Specifications	3
Maintenance	3
Kit contents	3
Auxiliary equipment and Add-ons	3
Installation notes	3
Update	3
Assembly instructions.....	4
Component layout diagram on the PCB.....	4
Populated PCB.....	4
Initial operation.....	4
Operation description	5
Operating principle of module kit WDMiba	5
SX bus connector	5
Connection of solenoid accessory and light signals	5
Settings.....	6
Operation mode.....	6
Pulse timers 1 and 2.....	6
Delayed output	6
Security monitoring system.....	6
Configuration (Programming).....	6
Example programming with TRIx Lok-Control 2000.....	7

Specifications

Measures

79mm x 76mm x 30mm

Power feed connection

The accessory module kit WDMiba requires a suitable external power supply according to the requirements of connected accessories. You should not exceed the following values:

Alternating current: 16V
Continuous current: 22V

We recommend our transformer with 16V AC, 70W output.

Output current

2A each output, total max. 4A.

Connections

1x solder pads for screw terminal blocks, 5mm pitch for SX bus
2x 5 solder pads for Selectrix data bus DIN mounted sockets
2 solder pads for terminal blocks for power supply
8x 3 solder pads for terminal blocks for connecting accessories to the decoder module

Switch/Display

Dip switch and a status LED to switch to programming mode.

Addresses

Depending of the central unit used: 1...103 / 111

Operating mode

For each output channel one of two timers can be selected. The timers can be set from 80 milliseconds to 20 seconds. A continuous output voltage is also possible.

Decoder configuration (Programming)

Decoder address and output mode of individual channels can be programmed in the program mode through SX bus. You need an input device for SX bus to do so.

Selectrix data bus connection

The accessory decoder WDMiba is connected to Selectrix bus (SX) using a cable with 5 pin DIN plugs (180°). The cable is shipped in EWDMiba kit (see auxiliary equipment). You can also build a suitable cable yourself if you need a cable with a different length.

Never connect different bus systems (PX, MX, SX0, SX1 etc.). You must never connect or disconnect bus plugs when the system is running. Unplug the control unit from its power supply first.

Assembly Notes

The accessory decoder kit WDMiba is assembled following the instructions on the next page. For soldering the components on the printed circuit board, a soldering iron of 12 to 25 Watts or a soldering station with the temperature set to approx. 350°C is necessary together with 0.5 or 1.0 mm soldering wire with rosin flux. No special tools are required. Do not use soldering flux! Pay attention to solder in a speedy way not to overheat and destroy devices.

Non use of the kit

When the accessory module kit WDMiba is not used it shall be stored at a dry and clean location.

For any questions please consult the FAQ-Section of our website, first: www.firma-staerz.de.

Maintenance

Clumping of dust in combination with condensing liquids may under circumstances become conducting and affect the functionality of the accessory decoder kit WDMiba in a negative way. That's why the decoder kit should be cleaned from dust by blowing off or vacuuming off from time to time.

The usage of any kind of liquid for cleaning is expressly prohibited.

Kit contents

Please first verify that the kit contains all the listed items below.

General parts:

1x printed circuit board 79x76mm
1x LEDs red
1x voltage regulator 78L05
1x rectifier B80C1500
1x Push button

ICs:

2x 74HC259
1x socket for microprocessor
1x microprocessor „WD2“

Transistors:

16x BD677

Capacitors (marked):

2x Ceramic 100nF (104Z)
2x Elektrolyt 47µF
1x Elektrolyt 1000µF

Resistors (marked):

3x 100kOhm (brown, black, black, orange, brown)
2x 22kOhm (red, red, black, red, brown)
16x 1,8kOhm (brown, grey, black, brown, brown)
1x 680Ohm (blue, grey, black, black, brown)
2x 100Ohm (brown, black, black, black, brown)

Auxiliary equipment and Add-ons

The following accessories for the decoder module kit WDMiba are available:

Auxiliary equipment

- Accessory kit EWDMiba

Includes all connectors, spacer rings and screws as well as an SX bus cable.

- Flyback diodes

To control uncouplers and turnouts without end position detectors additional flyback diodes (SMD) **must be installed**. A suitable standard diode type is 1N4001..7 in SMD format and can be ordered from us under catalog number 208 (a kit of 16 diodes).

The flyout diodes are soldered on the bottom side of the PCB when all the other components have been installed first. See the drawing on the next page (bottom side of the PCB).

Functional Add-ons

- Accessory kit EP WDMot

Allows the connection of 4 motor-powered turnouts. To equip all 8 output channels with motor-powered turnouts 2 accessory kits EP WDMot are required.

Installation notes

Assembled accessory decoder module should be placed on an easy to reach and dry spot under the layout. Use plastic spacer rings or a suitable housing for the assembled kit (see auxiliary equipment).

You have to ensure that electrically conducting parts or rough dirt won't fall onto the board of accessory module kit WDMiba.

In operating mode all electrically conducting tools, devices, cables, etc. have to be kept away from the decoder kit WDMiba. The decoder WDMiba can be destroyed by negligently caused short circuits from the outside (Top and bottom side as well). In this case any kind of warranty vanishes.

Update

The microprocessor is the heart of the decoder module kit WDMiba, containing the software. Due to being mounted on a socket it can be exchanged in the case of a software update. Never use other microprocessors than those released for WDMiba. Disregard can cause destruction of the decoder module kit WDMiba, any kind of warranty vanishes.

Assembly instructions

Assemble the kit in the order of these instructions. All the components are placed on the top side of the printed circuit board (marked „Top“) as close to the PCB as possible and soldered on the bottom side of the board (marked „Bottom“). Use a bending tool (for example Conrad 425869) to bend devices. Cut the leads of components flush using a wire cutter after soldering.

Be careful when soldering components!

1. Resistors

Bend the resistor leads for 7.5 mm pitch. To facilitate placing components on the PCB, support the edges of the board with the help of two books, for instance, in order to leave enough space for the leads under the board. Insert the resistors on board aligning the coloured rings of all the resistors in the same way to make it easier to verify the size of resistors later. Place a suitable piece of wood or similar on top of the resistors on board. Turn the board together with the wood upside down. The underside of the board is now conveniently accessible for soldering the components.

Solder one end of each resistor and check that they are positioned properly before soldering the other end of each resistor.

Solder resistors by groups of similar value before proceeding to the next group.

R1, R2, R6: 100kOhm (brown, black, black, orange, brown)
 R3-R4: 22kOhm (red, red, black, red, brown)
 R5, R8: 100Ohm (brown, black, black, black, brown)
 R7: 680Ohm (blue, grey, black, black, brown)
 R9-R24: 1,8kOhm (brown, grey, black, brown, brown)

2. ICs and socket for microprocessor

Align the notches in the IC and the socket according to the drawing printed on the circuit board and the component layout diagram.

IC4, IC5: 74HC259

Socket: Socket for IC1

3. Push button

Place on the reserved spot accordingly and solder.

4. LED

The cathode of the LED is facing away from the edge of the PCB and marked with letter 'K' on the board. The shorter lead of the diode is the cathode and the collar is also flat on the cathode side.

5. Ceramic capacitors

C1, C2: 100nF (104)

6. Voltage regulator

Align the flat side (bearing the code 78L05) of the voltage regulator towards the SX sockets.

7. Transistors

All transistors can be assembled simultaneously when proceeding as with resistors. Observe the orientation! Transistors T1 to T8 are installed with their metallic side facing the SX socket end of the PCB. Transistors T9 to T16 are installed with their printed side facing the SX socket end of the PCB.

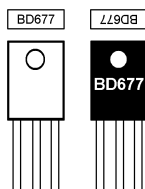

8. Rectifier

The rectifier has to be placed in the same height as the transistors. Place the rectifier on PCB with its' negative pole (-) facing the push button.

9. Electrolytic capacitors – Observe the polarity!

The longer lead is the positive pole and must be facing the SX sockets.

C3, C4: 47µF
 C5: 1000µF

10. Quality control and mounting the PIC

When all the components are soldered on the PCB, verify that they are placed according to the silkscreen layout on the PCB and that all the components are oriented properly. Check that all the solder points on the reverse side of the PCB look correct. Note especially if there are any undesired solder bridges between solder pads.

After quality control align the notches of the microprocessor according to the drawing printed on the circuit board and the component layout diagram.

IC1: PIC „WD2“

11. (Flyback diodes)

Flyback diodes are soldered in place as shown in the drawing „Bottom side of the PCB“. For each output channel the cathode end (marked with a stripe) of the diodes must be soldered to the shared output pin (b).



Component layout diagram on the PCB

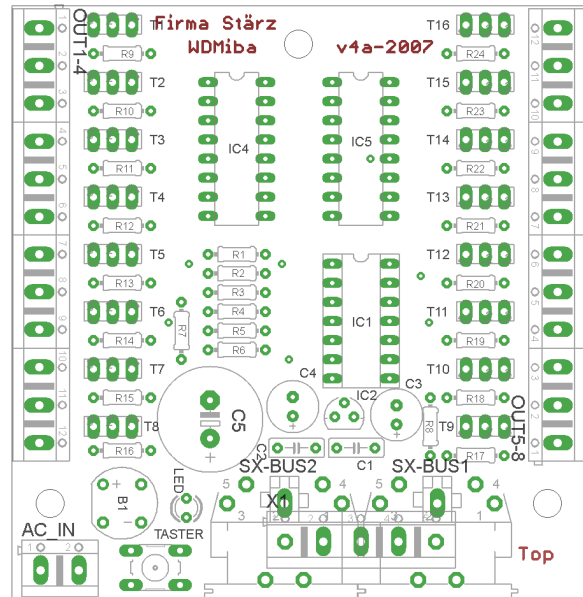

Populated PCB

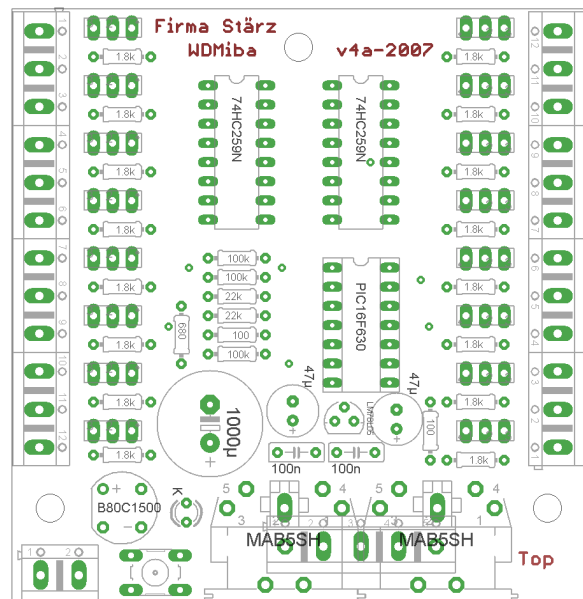

Initial operation

Accessory decoder's SX address, two pulse timers for pulse length and output mode and timer selection for each output channel can be programmed in the decoder permanently. For configuring decoder settings a data entry device such as our SPF-PIC, Lok-Control 2000, Control-Handy or a computer with software suitable for configuring decoders is required. You'll receive such a programme at our on demand.

Decoder must be connected to Selectrix data bus for configuring its' settings. Note that decoder programming uses SX channels (Selectrix addresses) 0 to 3 temporarily and the previous contents of these channels is erased.

Operation description

Operating principle of module kit WDMiba

Accessory decoder WD-2 monitors constantly status information of its' own bus address in the Selectrix bus and switches accordingly the state of its' output channels. The decoder has 8 output channels with double output terminals (one pair for "On"-setting and one pair for "Off"-setting).

The decoder has two alternative pulse timer settings and each output channel is configured to use one of the two. For instance, one of the two pulse timers can be for continuous output current suitable for a light signal and the other one can be a pulse with finite length, suitable for turnout solenoids and similar.

SX bus connector

SX bus devices are normally chained using five pin DIN plugs (180 degrees). Alternatively the accessory decoder module WDMiba can be connected to other components with a cable soldered permanently on the PCB. Normal multi-wire cables or individual wires can be used up to 50 m length without problems. The optional accessories kit EWDMiba uses the following colour coding (**may vary**):

T0 (Clock signal):	black
T1 (Central unit output):	red
Gnd (Signal ground):	blank
D (Central unit input):	white
+B (Operating voltage +20V):	yellow

Connection scheme of SX Bus

SX bus cable

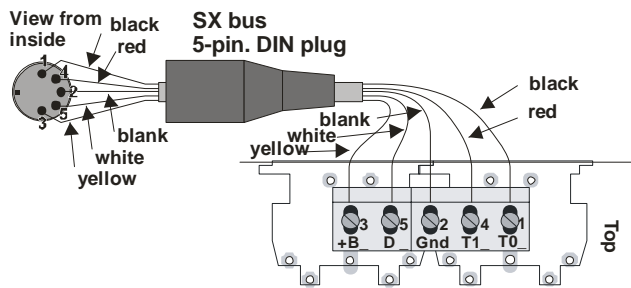

Be careful when preparing SX bus cables! If the wires are connected the wrong way, it may damage the system components!

Connection of solenoid accessory and light signals

Power supply voltage must be adapted to the requirements of connected accessories:

Turnouts, semaphore signals and uncouplers with coils accept maximum 16V alternating current. Light signals will need a somewhat lower voltage since the actual output voltage after the smoothing capacitor of the rectifier circuit is 1.4 times the voltage of the input alternating current. Light signals equipped with LEDs designed for 16 V AC should be fed with either 11 V AC or the value of the LED resistor should be increased respectively.

Connections of output channels

Pin	Turnout	Signal	Uncoupler
a:	Tangent	Stop	Not used
b:	+ VS	+ VS	+ VS
c:	Turnout	Go	Activate

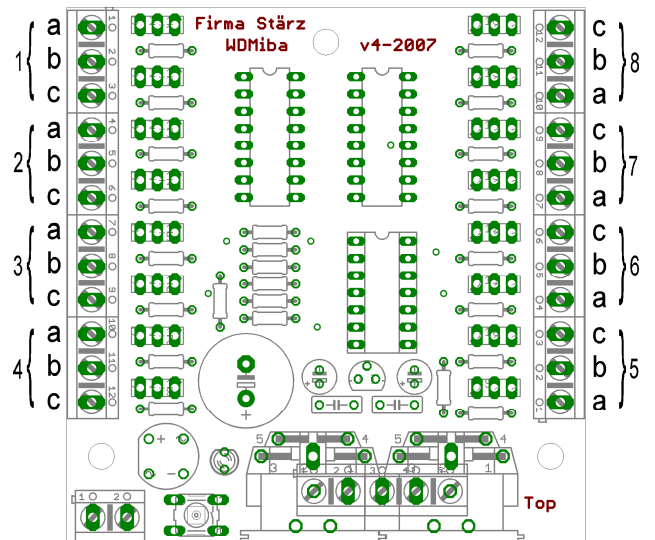
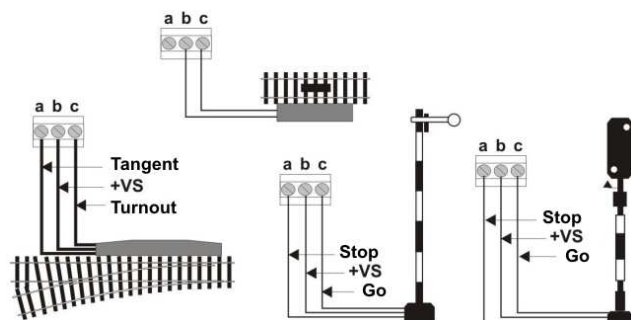

Turnout configuration

Normal position of turnouts is usually tangent position. If, however, the main line direction is in turnout position, the turnout can be wired to the decoder accordingly by swapping wires a and c.

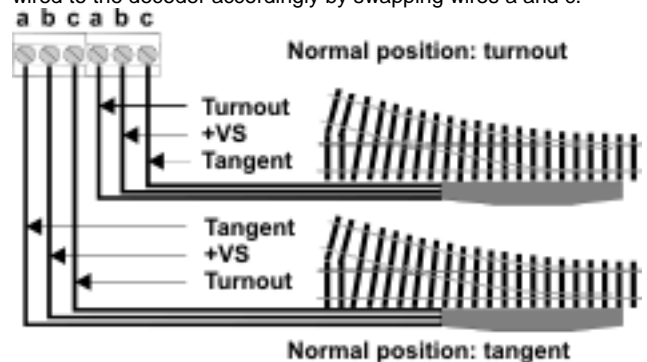

Turnouts wired in tandem

Using maximum two turnout motors wired in tandem is possible. Make sure that the two motors are identical.

Three-way turnout

A three way turnout is wired like two individual normal turnouts connected to two accessory decoder output channels. Before switching to turnout position, the opposite side should be switched to tangent position.

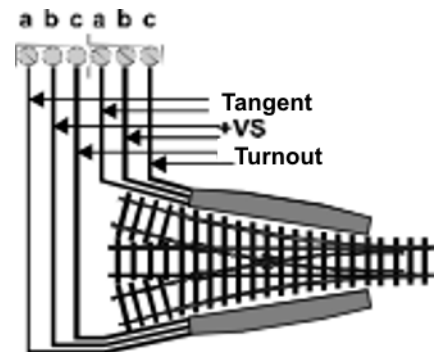

Light signal

Set the decoder output channel for continuous current. In order to avoid too high voltage over signal lamps, the common terminal (white) can be alternatively connected to decoder's power connector for AC.

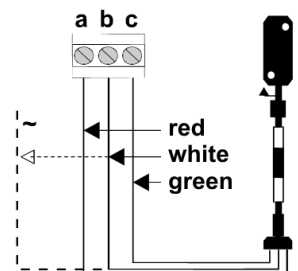

Light signal with train protection

Usually a remote control switch (relay) with two changeover switches is used with light signals for train protection. Remote control switch is connected to the outputs of a decoder channel. The switch controls signal lights and track current. Set the decoder channel to operate in pulse mode for remote control switches with or without end position detectors.

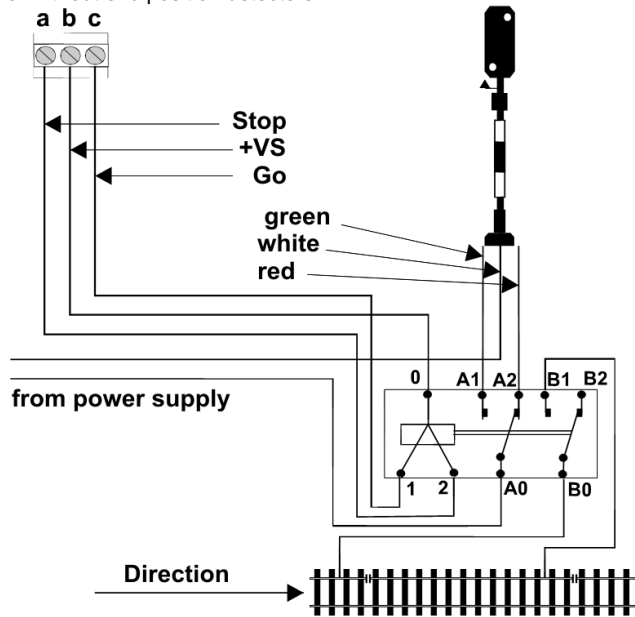

Settings

Operation mode

Solenoid powered accessories often have different requirements for the duration of current pulse to operate them. For instance, a turnout with a double solenoid and limit stop can usually be operated with a 0.5 to 1 second pulse length. Theoretically it is possible to operate this type of turnout with continuous current, but if the limit stop is not working, the solenoid will get damaged. Solenoid turnouts without limit stop should be controlled with pulses lasting 0.2 to 0.5 seconds.

Uncoupler tracks should not be operated with continuous current. Instead, select a pulse with a length of up to 20 seconds for uncouplers.

If we connect double solenoid turnouts and uncouplers in the same decoder, we can set the timer 1 to 0.5 to 1 second pulse for turnouts and timer 2 to a longer pulse of up to 20 seconds more suitable for an uncoupler.

To allow controlling accessory types with different current requirements, for each of decoder's eight output channels the timer to use can be selected individually. Both timers (1 and 2) can have either a pre-determined pulse length value or set to continuous current.

Operation mode pulse output

Operating a turnout requires a current pulse of finite length. Let's assume we set pulse timer 1 value to 1.2 seconds and configure the turnout to use pulse timer 1 in the accessory decoder. When the position of the turnout is switched from tangent to turnout, accessory decoder will give a 1.2 second pulse in output terminals corresponding to the connected turnout solenoid for turnout position. After the 1.2 s pulse, there is no current in the output channel. To switch the turnout to tangent position, the decoder will send a 1.2 s pulse to terminals of tangent position.

Operation mode continuous output

A light signal requires a continuous current output. In this case we can set pulse timer 2 to continuous operation. Decoder output channel configured to use pulse timer 2 will in this case have a continuous output in its' terminals currently selected.

Pulse timers 1 and 2

Both timers of the accessory module kit WDMiba are equal which means that they can be programmed independently to any pulse duration time between 0.08s (80ms) and 20 seconds with 80ms

increments, by selecting values from 1 to 254. Both timers can also be set to identical pulse lengths or continuous current mode (by programming value 255).

For each of the 8 decoder output channel one of those 2 timers can be chosen.

Timer 1 is used for all accessory decoder output channels where operation mode 0 is selected.

Timer 2 is used for all accessory decoder output channels where operation mode 1 is selected.

Delayed output

In computer controlled and other automatic layouts several turnouts or signals are typically switched simultaneously. This could result in excessive power consumption which exceeds the output capacity of the decoder. To prevent problems due to current peaks decoder outputs configured for pulse type outputs are activated with 80 ms delay between them when operated simultaneously. For channels set to continuous current output, there is no delay between them in simultaneous operation.

Security monitoring system

Poorly laid wiring or malfunctions of system components may result in a situation where a pulse type output is not switched off in time. This can cause overheating or even burn a solenoid connected to decoder output.

Accessory decoder WD-2 is equipped with a security monitoring system (Watchdog) which cuts off the output current of all output channels after about 2 seconds when an output pulse is not terminated in time normally due to SX system malfunctions.

SX address of the decoder module kit WDMiba

Decoders Selectrix bus address (channel) can have any value in the range 1 to 111. Some central units reserve bus addresses 104 to 111 for other purposes in which case they should not be assigned to accessory decoder.

SX bus addresses 0 to 3 are used to represent decoder's internal data registers during programming of the accessory decoder and some other static decoders and programming will clear the previous contents of any decoder in these addresses. Therefore using SX addresses 0 to 3 as decoder's SX address should be avoided if possible.

Configuration (Programming)

The address, operation mode and the two timers are defined by programming. To do so, follow the example on the last page.

Configurations in overview

Channel 0:	Address	1 to 103 / 111 (80)
	(Channel)	see table of addresses
Channel 1:	Operation mode (selectable for each output):	
	Bit value 0 (Off, "0" or "-")	uses timer 1
	Bit value 1 (On, "1" or "/")	uses timer 2
Channel 2:	Timer 1	1 to 254, 255 (16)
	Pulse length: 1 bis 254: (80ms increments)	
	Continuous current: 255 (all bits 1)	
	Factory setting: 16 = pulse length 1,2 seconds.	
Channel 3:	Timer 2	1 to 254, 255 (255)
	Pulse length: 1 bis 254: (80ms increments)	
	Continuous current: 255 (all bits 1)	
	Factory setting: 255 = continuous current	

Reset to saved values

By entering value 0 for SX address, timer 1 or timer 2 resets the according setting to it's previously saved value.

Factory settings:

SX address: 80
 Operation mode: 0 0 0 0 0 0 0
 (all output channels use timer 1)
 Timer 1: 16 (1.28 seconds)
 Timer 2: 255 (continuous current output)

If you enter an SX address with a value greater than 111, it will be reset to factory default setting 80.

Setting SX address to 255 (bits: 11111111) resets all decoder settings to their factory default settings.

Example programming with TRIX Lok-Control 2000

Enter programme mode:

Set Central unit to STOP.

Push MODE at Lok Control 2000 to enter function mode.



Press the programm button of accessory decoder.

The current configuration settings are copied to channels (SX addresses) 0 to 3 of the central unit.



Enter decoder-address (in Lok Control):
Select Channel (address) 00.

Current decoder address of accessory module kit WDMIBA is displayed (Example: Address 86):



Clear old decoder address

(Example: for address 86 press keys 2, 4, 5 and 7):



Enter new decoder address

(Example: address 34 press keys 2 and 6):



Enter operation mode for each output channel:

Select Channel (address) 01.

Current settings of all outputs are displayed. (Example: timer 2 selected for channels 3, 4 and 6, all the others use timer 1):

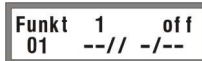

Clear operation mode selection

(Example: press keys 3, 4 and 6):



Enter new operation modes

(Example: use timer 2 for outputs 7 and 8 by pressing keys 7 and 8, all the other outputs will use timer 1):



Enter timer 1:

Select Channel (address) 02.

Current value of timer 1 is displayed. (Example: bit 4 on means that the time is 0.64 s):



Clear timer 1 value

(Example: press key 4):



Enter new value for timer 1

Enter value for timer 1 binary (Example: 8 seconds press keys 3, 6 and 7):



Enter timer 2:

Select Channel (address) 03.

Current value of timer 2 is displayed in binary (Example: all bits are on ("1") equals continuous output current):



Clear timer 2 value

(Example: press all keys 1 to 8):



Enter new value for timer 2

Enter value for timer 2 binary (Example: 0,16 seconds by key 2):



Exit programme mode:

Press the programme button on decoder or set the central unit to ON.

The values from channels (addresses) 0 to 3 are copied and stored in the decoder.

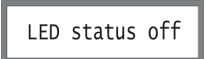

Decoder status LED blinks three times to confirm the data storage while all the bits of channel 0 are turned on and off twice. When ready, the status LED of the decoder is turned off.

Timers 1 and 2:

Pulse length is calculated by summation of the separate bit values (1 to 254) multiplied with the increment (0.08 s = 80 ms)

Bit	1	2	3	4	5	6	7	8
Value	1	2	4	8	16	32	64	128
Pulse	0,08	0,16	0,32	0,64	1,28	2,56	5,12	10,24

Value 255 (all bits ON) selects continuous current.

Examples of bit settings for various pulse lengths (in seconds):

Bit	1	2	3	4	5	6	7	8
Value	1	2	4	8	16	32	64	128
0,4	/	-	/	-	-	-	-	-
0,8	-	/	-	/	-	-	-	-
4,0	-	/	-	-	/	/	-	-
16,0	-	-	-	/	-	-	/	/
20,0	-	/	-	/	/	/	/	/
Continuous	/	/	/	/	/	/	/	/

Bit:	1	2	3	4	5	6	7	8
Value	1	2	4	8	16	32	64	128
Address 0	-	-	-	-	-	-	-	-
1	/	-	-	-	-	-	-	-
2	-	/	-	-	-	-	-	-
3	/	/	-	-	-	-	-	-
4	-	-	/	-	-	-	-	-
5	/	-	/	-	-	-	-	-
6	-	/	/	-	-	-	-	-
7	/	/	/	-	-	-	-	-
8	-	-	-	/	-	-	-	-
9	/	-	-	/	-	-	-	-
10	-	/	-	/	-	-	-	-
11	/	/	-	/	-	-	-	-
12	-	-	/	/	-	-	-	-
13	/	-	/	/	-	-	-	-
14	-	/	/	/	-	-	-	-
15	/	/	/	/	-	-	-	-
16	-	-	-	-	/	-	-	-
17	/	-	-	-	/	-	-	-
18	-	/	-	-	/	-	-	-
19	/	/	-	-	/	-	-	-
20	-	-	/	-	/	-	-	-
21	/	-	/	-	/	-	-	-
22	-	/	/	-	/	-	-	-
23	/	/	/	-	/	-	-	-
24	-	-	-	/	/	-	-	-
25	/	-	-	/	/	-	-	-
26	-	/	-	/	/	-	-	-
27	/	/	-	/	/	-	-	-
28	-	-	/	/	/	-	-	-
29	/	-	/	/	/	-	-	-
30	-	/	/	/	/	-	-	-
31	/	/	/	/	/	-	-	-
32	-	-	-	-	/	-	-	-
33	/	-	-	-	/	-	-	-
34	-	/	-	-	/	-	-	-
35	/	/	-	-	/	-	-	-
36	-	-	/	-	/	-	-	-
37	/	-	/	-	/	-	-	-
38	-	/	/	-	/	-	-	-
39	/	/	/	/	/	-	-	-

Bit	1	2	3	4	5	6	7	8
Value	1	2	4	8	16	32	64	128
Address 40	-	-	-	/	-	/	-	-
41	/	-	-	/	-	/	-	-
42	-	/	-	/	-	/	-	-
43	/	/	-	/	-	/	-	-
44	-	-	/	/	-	/	-	-
45	/	-	/	/	-	/	-	-
46	-	/	/	/	-	/	-	-
47	/	/	/	/	-	/	-	-
48	-	-	-	-	/	/	-	-
49	/	-	-	-	/	/	-	-
50	-	/	-	-	/	/	-	-
51	/	/	-	-	/	/	-	-
52	-	-	/	-	/	/	-	-
53	/	-	/	-	/	/	-	-
54	-	/	/	-	/	/	-	-
55	/	/	/	-	/	/	-	-
56	-	-	-	/	/	/	-	-
57	/	-	-	/	/	/	-	-
58	-	/	-	/	/	/	-	-
59	/	/	-	/	/	/	-	-
60	-	-	/	/	/	/	-	-
61	/	-	/	/	/	/	-	-
62	-	/	/	/	/	/	-	-
63	/	/	/	/	/	/	-	-
64	-	-	-	-	-	/	-	-
65	/	-	-	-	-	/	-	-
66	-	/	-	-	-	/	-	-
67	/	/	-	-	-	/	-	-
68	-	-	/	-	-	/	-	-
69	/	-	/	-	-	/	-	-
70	-	/	/	-	-	/	-	-
71	/	/	/	-	-	/	-	-
72	-	-	-	/	-	/	-	-
73	/	-	-	/	-	/	-	-
74	-	/	-	/	-	/	-	-
75	/	/	-	/	-	/	-	-
76	-	-	/	/	-	/	-	-
77	/	-	/	/	-	/	-	-
78	-	/	/	/	-	/	-	-
79	/	/	/	/	-	/	-	-

Bit	1	2	3	4	5	6	7	8
Value	1	2	4	8	16	32	64	128
Address 80	-	-	-	-	/	-	/	-
81	/	-	-	-	/	-	/	-
82	-	/	-	-	/	-	/	-
83	/	/	-	-	/	-	/	-
84	-	-	/	-	/	-	/	-
85	/	-	/	-	/	-	/	-
86	-	/	/	-	/	-	/	-
87	/	/	/	-	/	-	/	-
88	-	-	-	/	/	-	/	-
89	/	-	-	/	/	-	/	-
90	-	/	-	/	/	-	/	-
91	/	/	-	/	/	-	/	-
92	-	-	/	/	/	-	/	-
93	/	-	/	/	/	-	/	-
94	-	/	/	/	/	-	/	-
95	/	/	/	/	/	-	/	-
96	-	-	-	-	/	/	-	-
97	/	-	-	-	/	/	-	-
98	-	/	-	-	/	/	-	-
99	/	/	-	-	/	/	-	-
100	-	-	/	-	-	/	/	-
101	/	-	/	-	-	/	/	-
102	-	/	/	-	-	/	/	-
103	/	/	/	-	-	/	/	-
(*) 104	-	-	-	/	-	/	/	-
(*) 105	/	-	-	/	-	/	/	-
(*) 106	-	/	-	/	-	/	/	-
(*) 107	/	/	-	/	-	/	/	-
(*) 108	-	-	/	/	-	/	/	-
(*) 109	/	-	/	/	-	/	/	-
(*) 110	-	/	/	/	-	/	/	-
(*) 111	/	/	/	/	-	/	/	-

Note:
Addresses with an asterisk are not available in some cases.
Check the documentation of your central unit (SX bus extension)

Selectrix is a registered trademark by Trix Nuremberg.

Modellbahn Digital Peter Stärz, Dresdener Str. 68, D-02977 Hoyerswerda

Illustrations and technical data are subject to change. We are not responsible for printing or typographical errors.

Printable version of 13.02.2010