

MODELLBAHN DIGITAL

Peter Stärz – Dresdener Str. 68 – 02977 Hoyerswerda - ☎ 03571/404027
www.firma-staerz.de - peter.staerz@t-online.de



Short circuit proof reverse loop module for all digital control systems based on dynamic occupancy detection

KS-PIC
v1-2007
 with / without
 turnout control

Reverse loop module KS-PIC is a device for adjusting polarity of model railway reverse loops automatically. The module monitors sensor track blocks and switches the polarity of the reverse loop accordingly. Reverse loop module KS-PIC can be used with all digital control systems.

There are two versions of the module: with or without integrated turnout control (WS).

Operating Principle

Every reverse loop is equipped with two sensor track sections, one at both ends of the reverse loop section. A train entering the reverse loop is detected when it reaches the first sensor track. The polarity of the reverse loop is then adjusted dynamically for the incoming train. For train detection to work it is not necessary to have either a locomotive or an illuminated coach in front of the train. The minimum requirement is at least one axle with metallic wheels in the train. If, however, the reverse loop is monitored with a separate block occupancy detector (sensor track blocks 1 and 2 and the reverse loop block), current drain sensors of the occupancy detector will require either a locomotive or an illuminated coach in the train. The entry sensor track block detects the train entering the reverse loop and switches the polarity of the loop block accordingly in order to avoid a short circuit. When the train reaches the exit side sensor block, the polarity of the loop section is inverted again to match the polarity of the track section following reverse loop thus avoiding a risk of short circuit again.

An external power supply for the module is not required since the digital power for the track provides the power for the module as well. If the integrated turnout control is used, an external power supply is needed for the turnouts.

Assembly notes

Reverse loop module kit KS-PIC is assembled following the instructions on the next page. For soldering the components on the printed circuit board, a soldering iron of 12 to 25 Watts or a soldering station with the temperature set to approx. 350°C is necessary together with 0.5 or 1.0 mm soldering wire with rosin flux. No special tools are required. The module is equipped with screw terminal blocks for track connections. Do not use solder grease!

Installation notes

Assembled reverse loop module should be placed on an easy to reach and dry spot under the model railway layout. Use plastic spacer rings or a suitable housing for the assembled kit.

Block occupancy detection in reverse loop

Block occupancy detection is possible for the entire reverse loop section. The section is divided in three blocks and the occupancy data of each of the three blocks can be forwarded to a block occupancy detector unit. A detector unit that can monitor several blocks (e.g. Selectrix detectors) will need three free block detection decoders for the reverse loop. The loop can be monitored by several occupancy detector units; if necessary (e.g. not enough free decoder circuits left in one unit). The reverse loop does not require a dedicated detector unit and the remaining decoder circuits of one unit can be used for other track blocks in the layout.

The length of the reverse loop track block must be at least equal to the longest train that will travel via the reverse loop.

Pin arrangement of terminal blocks:

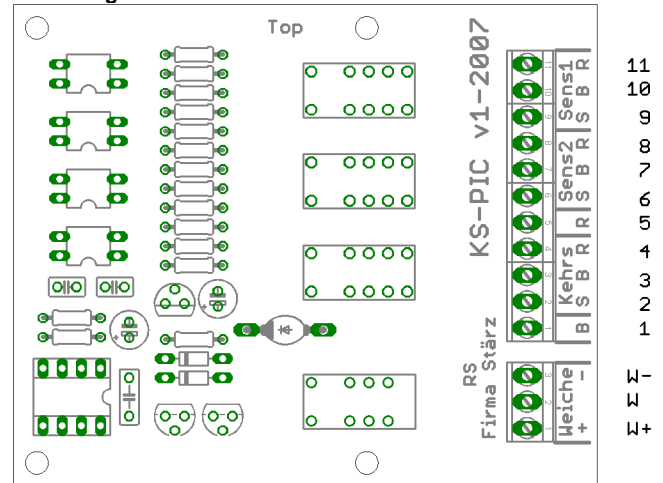

Specifications:

Size:

64 x 77mm

Power supply:

The module is powered by track voltage or the digital voltage from booster or central unit.

Operating current:

5mA (idle)
 50mA (during the switching operation lasting for about 30ms)

Output current:

About 3A (continuous)

Connections (Screw terminal blocks with 3.5mm pitch):

- 3 terminals for sensor track block 1:
 - 11 Red (Sens1 R)
 - 10 Blue (Sens1 B)
 - 9 Occupancy detection (Sens1 S)
- 3 terminals for sensor track block 2:
 - 8 Red (Sens2 R)
 - 7 Blue (Sens2 B)
 - 6 Occupancy detection (Sens2 S)
- 3 terminals for the reverse loop block
 - 4 Red (Kehrs R)
 - 3 Blue (Kehrs B)
 - 2 Occupancy detection (Kehrs S)
- 2 terminals for power feed
 - 5 Red (R)
 - 1 Blue (B)

Kit contents:

Please verify that the kit contains all the components listed on the next page.

For further information, please refer to the FAQ section of our website at <http://www.firma-staerz.de>.

Module electrical connections:

To connect the reverse loop module the track forming the reverse loop has to be made up of 3 double side insulated consecutive rails. The insulated track sections are connected as follows:

Sensor track block 1 (S1, green, terminals {9, 10, 11}),

Reverse loop block (K, orange, terminals {2, 3, 4}) and

Sensor track block 2 (S2, green, terminals {6, 7, 8}).

The reverse loop block must be at least as long as the longest train that will travel through the loop. For sensor track blocks a length of 5 to 10 cm is sufficient. The correct wiring is vital for the proper functioning of KS-PIC reverse loop module. For all the three track sections there are three wires: Red (R), Blue (B) und Sensor (S) for the connection to a block occupancy detector unit. The wiring of a simple reverse loop is shown in the picture below. Some variations to the basic loop are also given and in some cases two reverse loop modules are required, but the same connection principles apply. Terminals 1 (B) and 5 (R) serve as the connection point to the rest of the model railway layout. They also supply the power to the reverse loop module and the track current for reverse loop track sections S1, K and S2. The basic wiring of the reverse loop module KS-PIC does not depend of the presence of a block occupancy detector unit. Wiring variations with or without a detector unit are shown below.

Even if the reverse loop is long enough for several occupancy detection blocks, the three blocks S1, K and S2 must always be placed in the same consecutive order next to each other. Additional blocks must be placed outside these three sections. Section K cannot be divided in several detection blocks.

If the reverse loop is only partially monitored for track occupancy (for instance, K monitored, S1 and S2 not), all the unused occu-

pancy signals must be wired together and to the terminal 1. (In our example the terminals 6, 9 and 1 would be wired together). If there is no occupancy detector unit at all, the terminals 1, 2, 6 and 9 must be wired together as shown in the illustration "Reverse loop without an occupancy detector" below.

In addition to the 11 terminals for connecting the track, there are three terminals for connecting a turnout (only in the version "mit WS") in the module. The wiring of a turnout is shown in the picture below: W- = branch, W+ = straight and ground. Note that these terminals supply a continuous current and therefore **the turnout motor or solenoid must be wired for end-off switching**. An external power supply is required for powering the turnout.

Testing

Before using the module to control trains in the reverse loop for the first time, the wiring of the module should be tested. This is best done using a light bulb (voltage 16V-19V, current 30mA - 50mA). When the power is switched on, simulate a locomotive in section S1 by connecting the light bulb on the left and the right rail in S1 (KS-PIC may switch the loop polarity). Now connect the light bulb between the blue rail of S1 and the blue rail of the track outside the loop sections (W-). If the lamp is on, the blue and red wires of section S1 are inverted. Next, test the section K by connecting the light bulb on the blue rail of sections S1 and K. If the lamp is on, red and blue wires of section K are inverted. Now simulate a locomotive on section S2 by connecting the light bulb on both rails of the section (again, KS-PIC may switch the loop polarity). Test the lamp on blue rails of S2 and K. If the light is on, the two wires of S2 are inverted.

Connection examples:

Reverse loop with an occupancy detector unit:

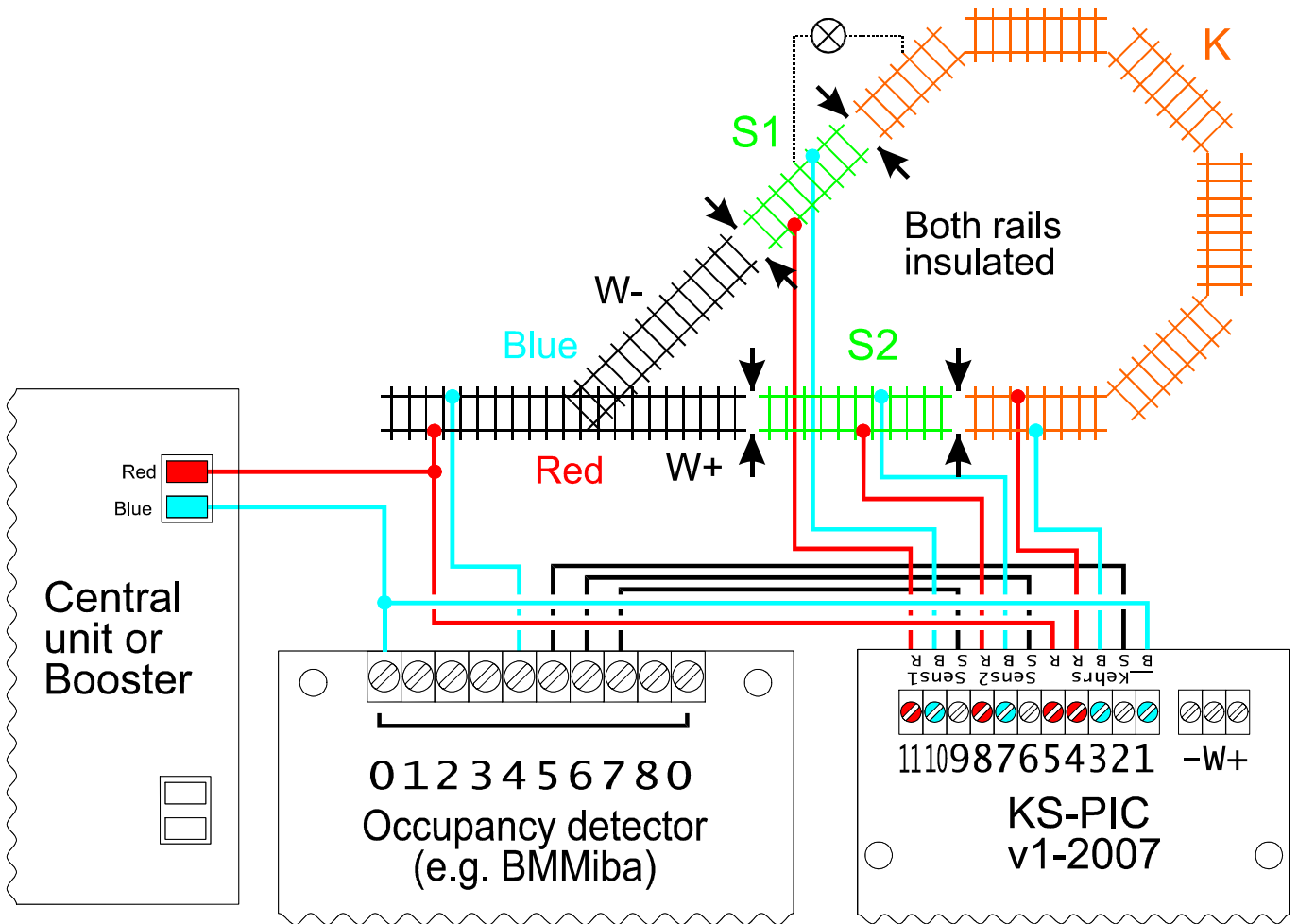

Reverse loop without an occupancy detector:

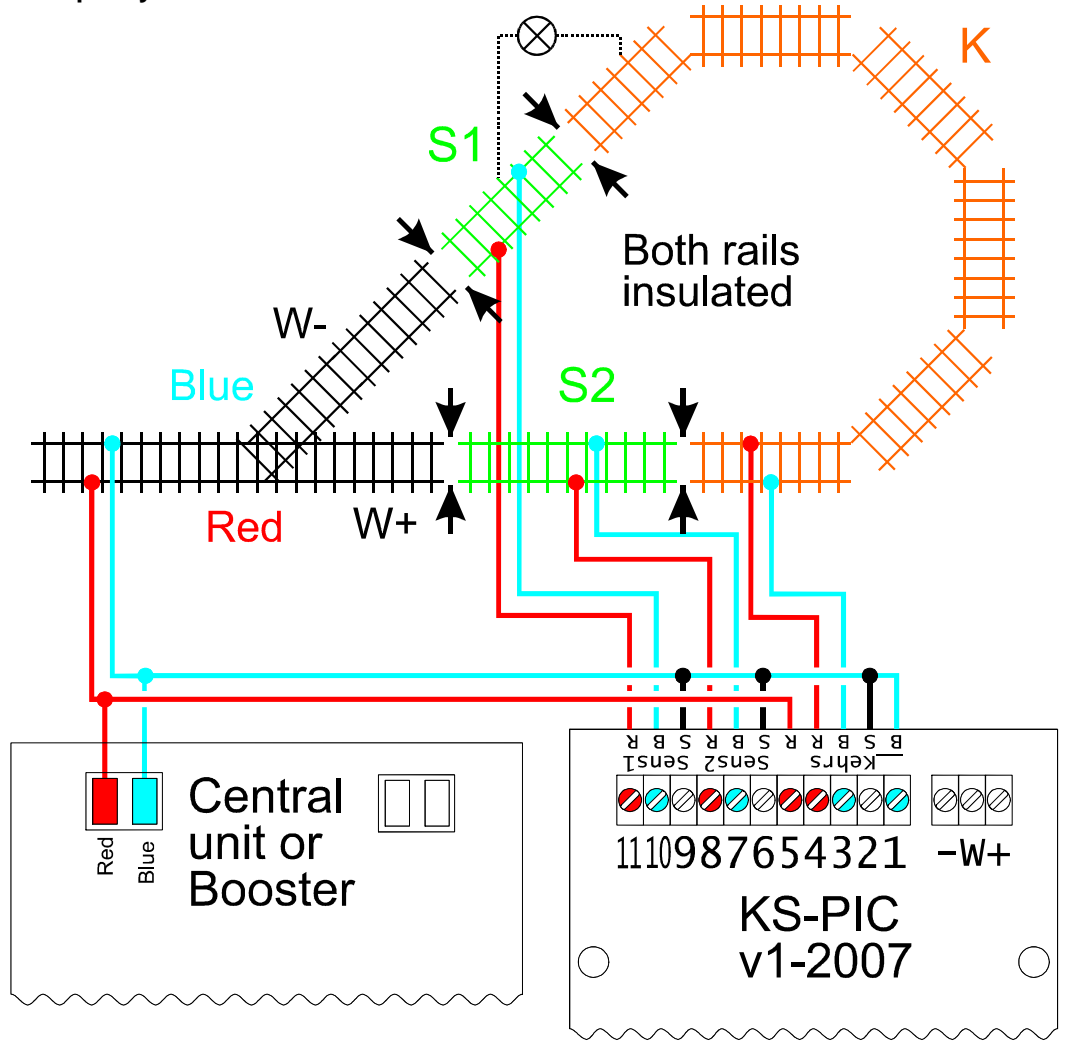

Reverse loop variations:

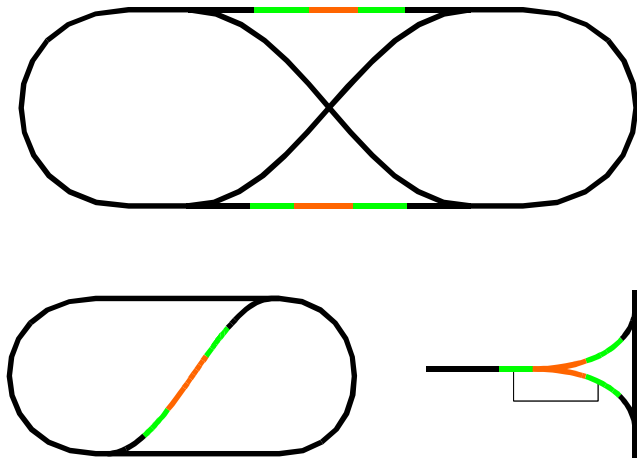

Connection of a turnout:

(applies only to module version "mit WS")

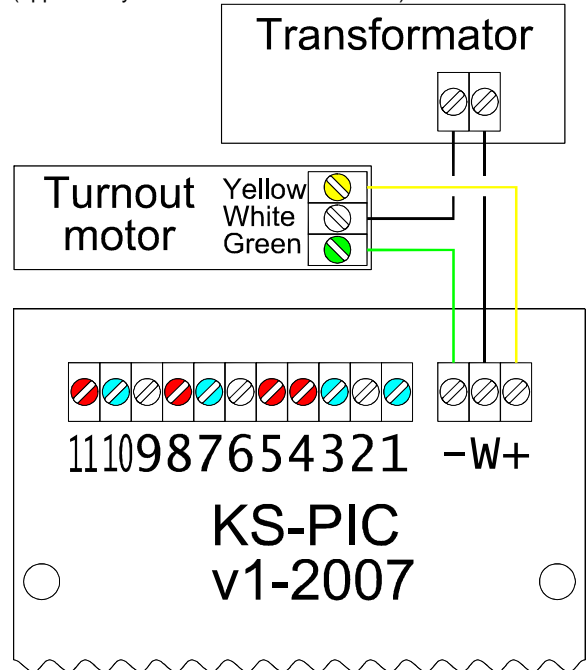

Selectrix is a registered trademark by Trix Nuremberg.
 Modellbahn Digital Peter Stärz, Dresdener Str. 68, D-02977 Hoyerswerda
 Illustrations and technical data are subject to change. We are not responsible for printing or typographical errors.

Printable version 19.01.2010